

NOTE:

1. ALL RADIUS .120 UNLESS NOTED

REVISION HISTORY					
REV	DATE	DESCRIPTION	CA	DWR	APVD
A	2/19/2019	RELEASED TO PRODUCTION	CA-00004559	PH	BB
B	1/9/2023	UPDATED SHEET FORMAT. UPDATED HUB MARKINGS	CA-00158501	ALA	PFH
C	6/9/2025	UPDATED SHEET FORMAT; DIM 12.255/12.245 RUNOUT TOL WAS .005; ADDED .125 X 45° CHAMFER	CA-00290694	DCA	BAB

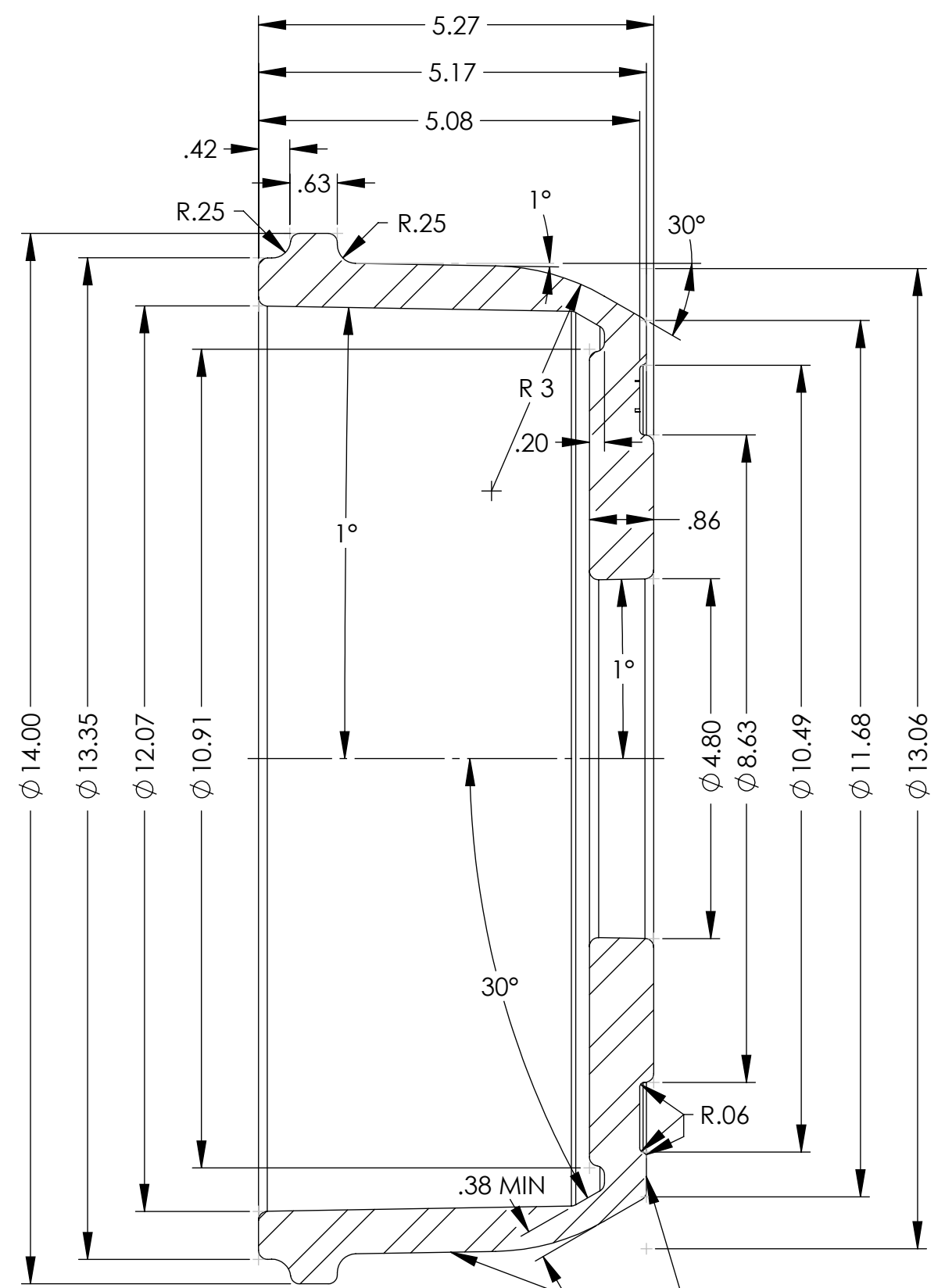

HUB MARKINGS
 -PER ES-040
 -PART NUMBER: 791397

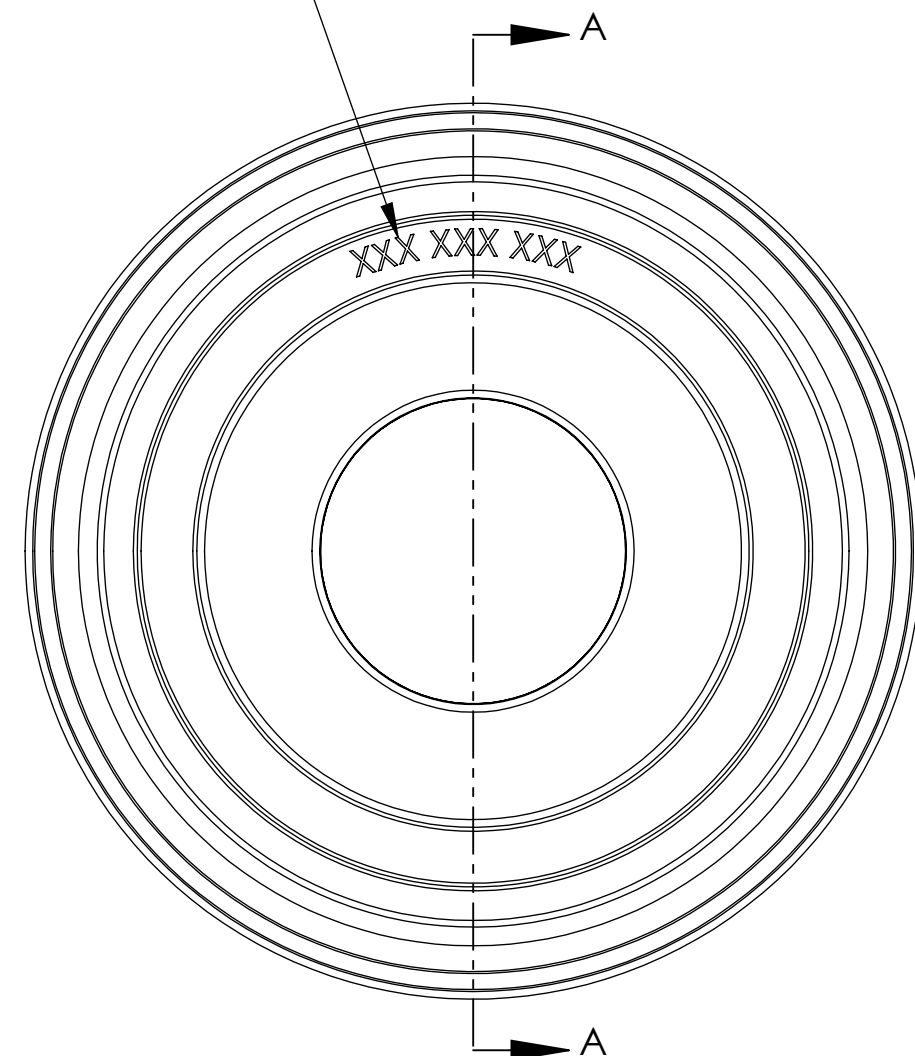

SECTION A-A
 SCALE 1 : 2

LOCATING AND CLAMPING AREAS
 MUST BE FREE FROM SWELLS OR
 SURFACE IRREGULARITIES

REFERENCE NUMBER:	
MATERIAL TYPE:	SAE J431 CI GR G3000
SURFACE QUALITY:	
NOM. MATERIAL THICKNESS: (EXCEPT AS NOTED)	
FINISH GOOD WEIGHT:	47.261
BLANK WEIGHT:	
BLANK SIZE:	

TITLE: BRAKE DRUM - CASTING/MACHINING - 865 - 10K SHORT						
UNLESS OTHERWISE SPECIFIED 1. ALL DIMENSIONS ARE IN INCHES 2. BREAK SHARP EDGES & DEBURR 3. MATERIAL & FINISH TO BE AS NOTED OR SUBSTITUTED WITH AN APPROVED AND TESTED EQUIVALENT		TOLERANCES (EXCEPT AS NOTED)	THE INFORMATION CONTAINED IN THIS DRAWING IS THE SOLE PROPERTY OF LIPPERT. ANY REPRODUCTION IN PART OR AS A WHOLE WITHOUT THE WRITTEN PERMISSION OF LIPPERT IS PROHIBITED.	LIPPERT™		
DECIMAL	.X ±.1 .XX ±.03 .XXX ±.015	FRACTIONAL ±1/16		DWG. NO. 791397	SIZE B	DATE: 5/29/2008
FILLETS R.015	FINISH ✓	ANGULAR ±1°		APPROVED BY PH	DRAFTSMAN PH	REV. C
THIRD ANGLE PROJECTION 				SCALE: 1:3	SHEET 1 OF 2	

NOTE:

1. PAINT PER ES - 035

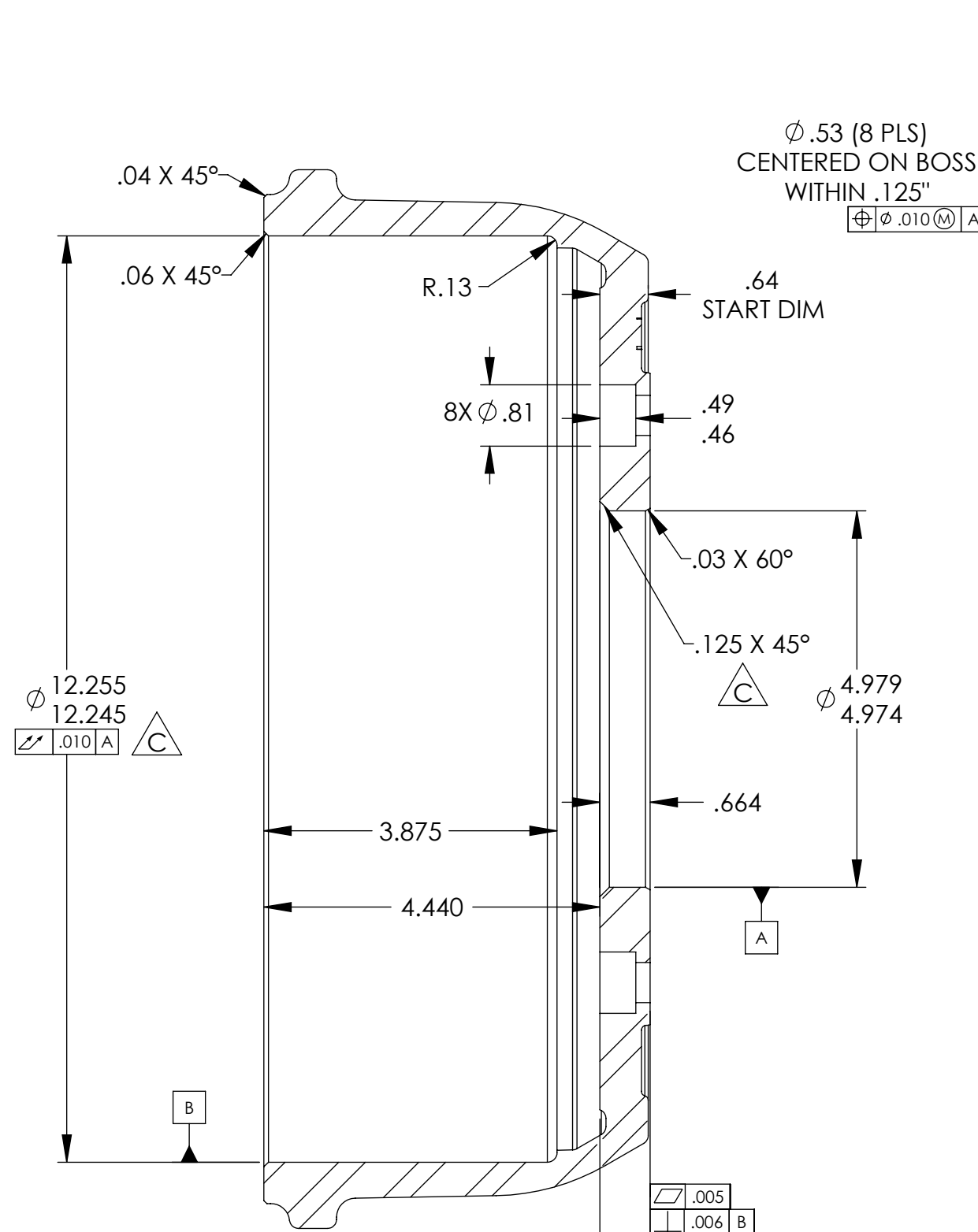

SECTION B-B
SCALE 1 : 2

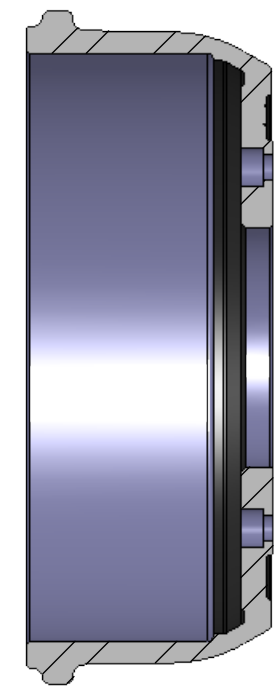
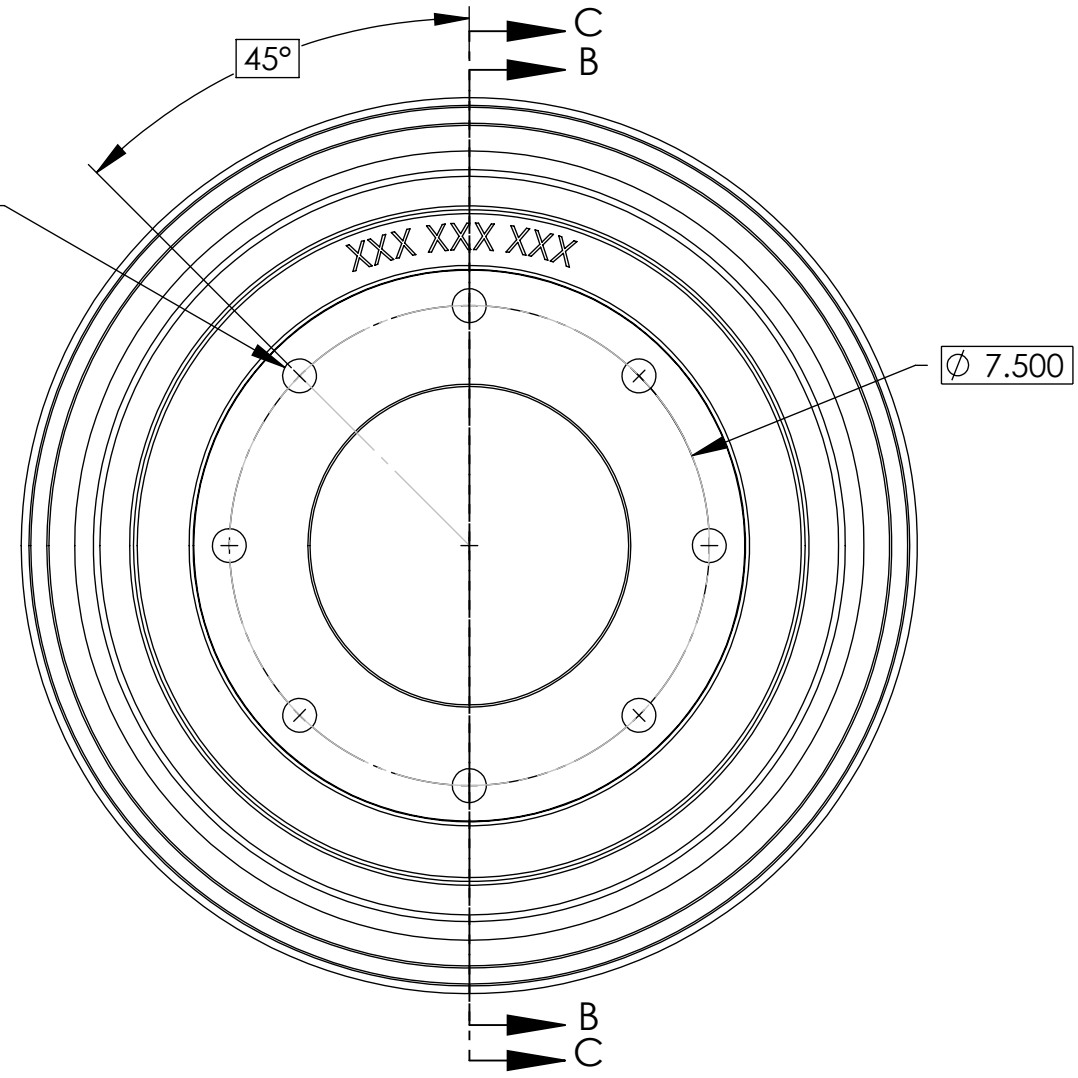

SECTION C-C
SCALE 1 : 4

REFERENCE NUMBER:	
MATERIAL TYPE:	SAE J431 CI GR G3000
SURFACE QUALITY:	
NOM. MATERIAL THICKNESS: (EXCEPT AS NOTED)	
FINISH GOOD WEIGHT:	38.069
BLANK WEIGHT:	
BLANK SIZE:	

TITLE: BRAKE DRUM - CASTING/MACHINING - 865 - 10K SHORT			
UNLESS OTHERWISE SPECIFIED 1. ALL DIMENSIONS ARE IN INCHES 2. BREAK SHARP EDGES & DEBURR 3. MATERIAL & FINISH TO BE AS NOTED OR SUBSTITUTED WITH AN APPROVED AND TESTED EQUIVALENT		TOLERANCES (EXCEPT AS NOTED)	THE INFORMATION CONTAINED IN THIS DRAWING IS THE SOLE PROPERTY OF LIPPERT. ANY REPRODUCTION IN PART OR AS A WHOLE WITHOUT THE WRITTEN PERMISSION OF LIPPERT IS PROHIBITED.
FILLETS R.015	FINISH ✓	DECIMAL .X ±.1 .XX ±.03 .XXX ±.015	
THIRD ANGLE PROJECTION		FRACTIONAL ±1/16	
		ANGULAR ±1°	
DWG. NO.	SIZE	DATE:	REV.
791397	B	5/29/2008	C
ENGINEER PH	DRAFTSMAN PH	APPROVED BY	SHEET 2 OF 2
		SCALE: 1:3	

